

EN standard

ODBOJNE KLAPNE / CHECK VALVES

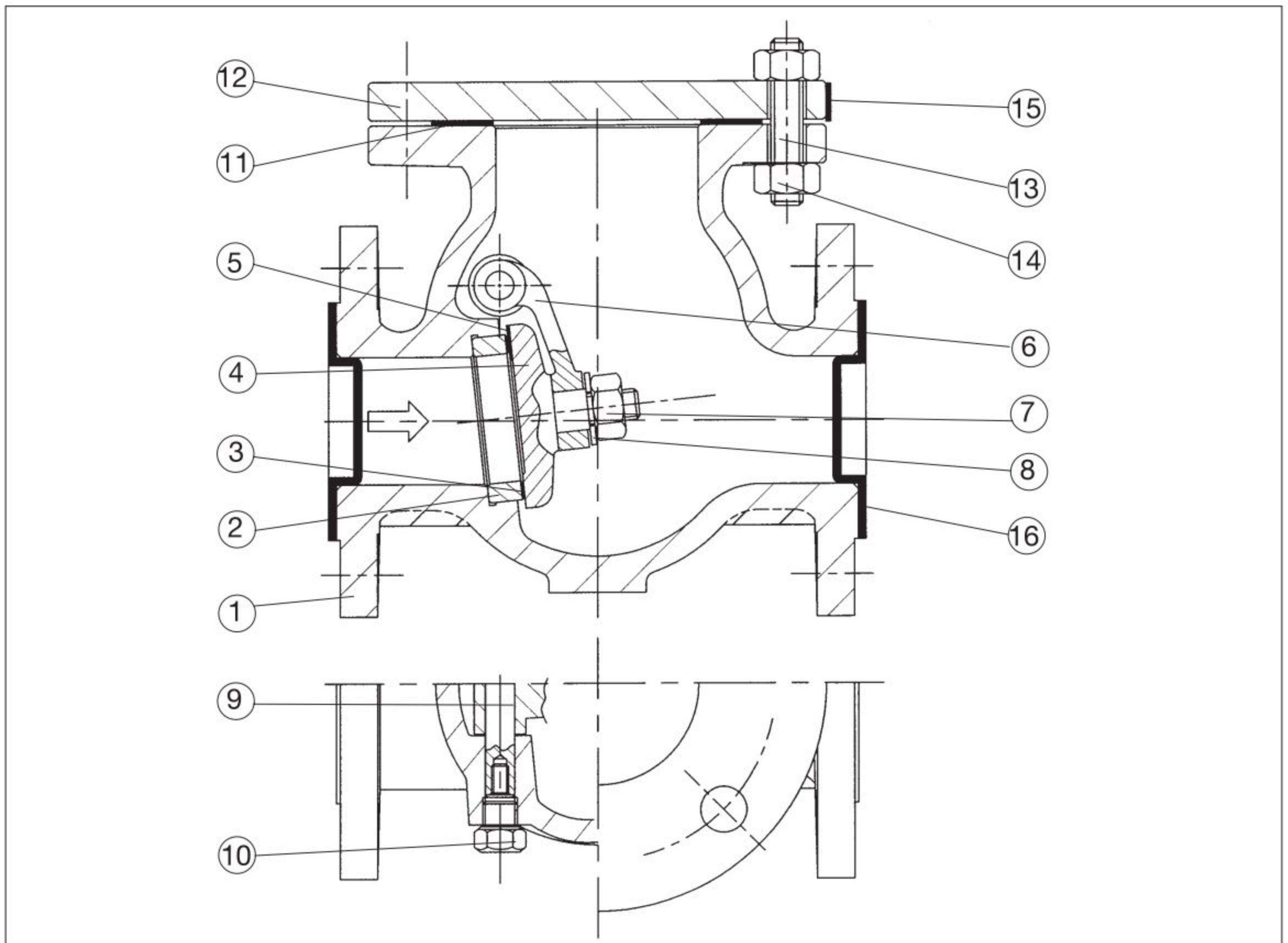

Part No	Part Name	Standard Material
1	Body	Cast Steel A216 Gr. WCB
2	Body Ring	2" - 6" alloy steel CA15, 8" and above A105
3	Body Seat Ring Face	Stainless Steel 13 Cr.
4	Disc	Cast Steel A216 Gr. WCB
5	Disc Seat Face	Stainless Steel 13 Cr.
6	Hinge	Cast Steel A216 Gr. WCB
7	Disc Nut	Carbon Steel A194 Gr. 2H
8	Disc Washer	Steel A307 Gr. B
9	Stem	Stainless Steel A182 Gr. F6
10	Plug	Steel A307 Gr. B
11	Gasket	Non asbestos or SWG F316
12	Bonnet	Steel St 37
13	Bonnet Stud Bolt	Alloy Steel A193 Gr. B7
14	Bonnet Stud Nut	Carbon Steel A194 Gr. 2H
15	Name Plate	Aluminium
16	End Cover	Plastic or Wooden